



Please write clearly in block capitals.

Centre number

Candidate number

Surname _____

Forename(s) _____

Candidate signature _____

I declare this is my own work.

GCSE PHYSICS

F

Foundation Tier Paper 1

Time allowed: 1 hour 45 minutes

Materials

For this paper you must have:

- a ruler
- a scientific calculator
- the Physics Equations Sheet (enclosed).

Instructions

- Use black ink or black ball-point pen. Pencil should only be used for drawing.
- Fill in the boxes at the top of this page.
- Answer **all** questions in the spaces provided.
- Do not write outside the box around each page or on blank pages.
- If you need extra space for your answer(s), use the lined pages at the end of this book. Write the question number against your answer(s).
- Do all rough work in this book. Cross through any work you do not want to be marked.
- In all calculations, show clearly how you work out your answer.

Information

- The maximum mark for this paper is 100.
- The marks for questions are shown in brackets.
- You are expected to use a calculator where appropriate.
- You are reminded of the need for good English and clear presentation in your answers.

For Examiner's Use	
Question	Mark
1	
2	
3	
4	
5	
6	
7	
8	
9	
10	
11	
TOTAL	



JUN2184631F01

IB/M/Jun21/E15

8463/1F

Answer **all** questions in the spaces provided.**0 1 . 1** A student investigated the three states of matter.

The arrangement of particles in the three states of matter are different.

Draw **one** line from each particle arrangement to the state of matter.**[2 marks]**

Particle arrangement

State of matter

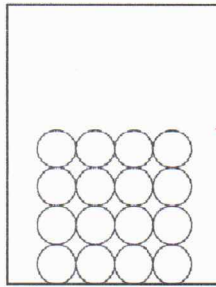

Solid

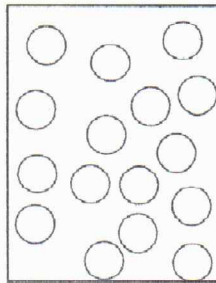
*Closely
packed*

Liquid

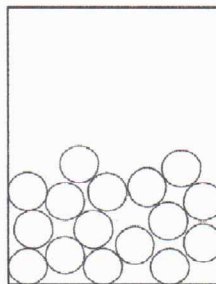
*Relatively
spaced out
than in
solids.*

Gas

*Particle
further away
from each
other and
randomly
moving.*

A large lump of ice was heated and changed state.

Figure 1 shows how the temperature varied with time.

Figure 1

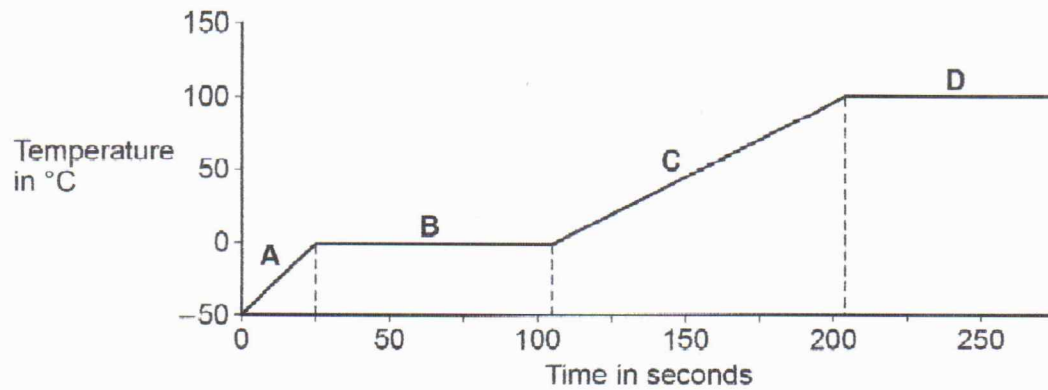

0 1 . 2 Which part of Figure 1 shows when the ice was melting?

[1 mark]

Tick (✓) one box.

A B C D

0 1 . 3 Which part of Figure 1 shows when the water was boiling?

[1 mark]

Tick (✓) one box.

A B C D

horizontal after/at 100°C

Question 1 continues on the next page

Turn over ►



0 1 . 4

Which property of the water particles changes as the temperature of the water increases?

[1 mark]

Tick (✓) one box.

The kinetic energy of the particles

particles move faster.

The mass of each particle

The number of particles

0 1 . 5

Calculate the thermal energy needed to melt 0.250 kg of ice at 0 °C.

specific latent heat of fusion of water = 334 000 J/kg

Use the equation:

thermal energy = mass × specific latent heat

[2 marks]

$$= 0.250 \times 334000$$

$$= 83,500$$

Thermal energy = 83,500 J



0 1 . 6

Complete the sentence.

Choose the answer from the box.

[1 mark]

condenses evaporates ionises sublimates

A substance is heated and changes directly from a solid to a gas.

The substance sublimates.

8

Turn over for the next question

Turn over ►



0 2

Figure 2 shows part of the National Grid linking a power station to consumers.

Figure 2

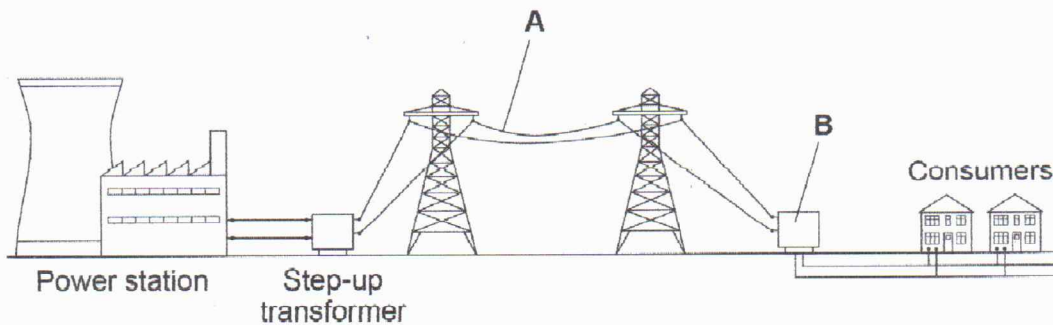

0 2 . 1

Name the parts of Figure 2 labelled A and B.

[2 marks]

A transmission cables

B step-down transformer

0 2 . 2

Electricity is transmitted through A at a very high potential difference.

What is the advantage of transmitting electricity at a very high potential difference?

[1 mark]

Tick (✓) one box.

A high potential difference is safer for consumers. Less thermal energy is transferred to the surroundings. Power transmission is faster.

*less current and so less
over heating of power cables*

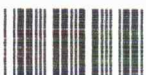

0 2 . 3

The power station generates electricity at a potential difference of 25 000 V.

The energy transferred by the power station in one second is 500 000 000 J.

Calculate the charge flow from the power station in one second.

Use the equation:

$$\text{charge flow} = \frac{\text{energy}}{\text{potential difference}}$$

[2 marks]

$$= \frac{500,000,000}{25,000}$$

$$= 20,000$$

Charge flow in one second = 20,000 C

Question 2 continues on the next page

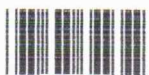

The electricity supply to a house has a potential difference of 230 V.

Table 1 shows the current in some appliances in the house.

Table 1

Appliance	Current in amps
Dishwasher	6.50
DVD player	0.10
Lamp	0.40
TV	0.20

0 2 4 Calculate the total power of all the appliances in Table 1.

Use the equation:

$$\text{power} = \text{potential difference} \times \text{current}$$

[3 marks]

$$\begin{aligned} \text{Total current} &= 6.50 + 0.10 + 0.40 + 0.20 \\ &= 7.20 \text{ A} \end{aligned}$$

$$\begin{aligned} \text{Power} &= V \times I \\ &= 230 \times 7.20 \\ &= 1656 \text{ W} \end{aligned}$$

Total power = 1656 W



0 2 . 5

Each appliance in **Table 1** is switched on for 2 hours.

Which appliance will transfer the most energy?

Give a reason for your answer.

[2 marks]

Appliance Dishwasher:Reason ($P = V \times I$ or $P \propto I$)
It has the largest current

0 2 . 6

The average energy transferred from the National Grid every second for each person in the UK is 600 J.

There are 32 000 000 seconds in one year.

Calculate the average energy transferred each year from the National Grid for each person in the UK.

[2 marks]

Energy per year = $600 \times 32\,000\,000$
= $19\,200\,000\,000$ JAverage energy transferred = 19,200,000,000 J

12

Turn over for the next question

Turn over ►

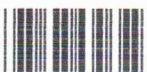

0 3

A student investigated the density of different fruits.

To determine the density of each fruit, the student measured the volume of each fruit.

Figure 3 shows the equipment the student could have used.

Figure 3

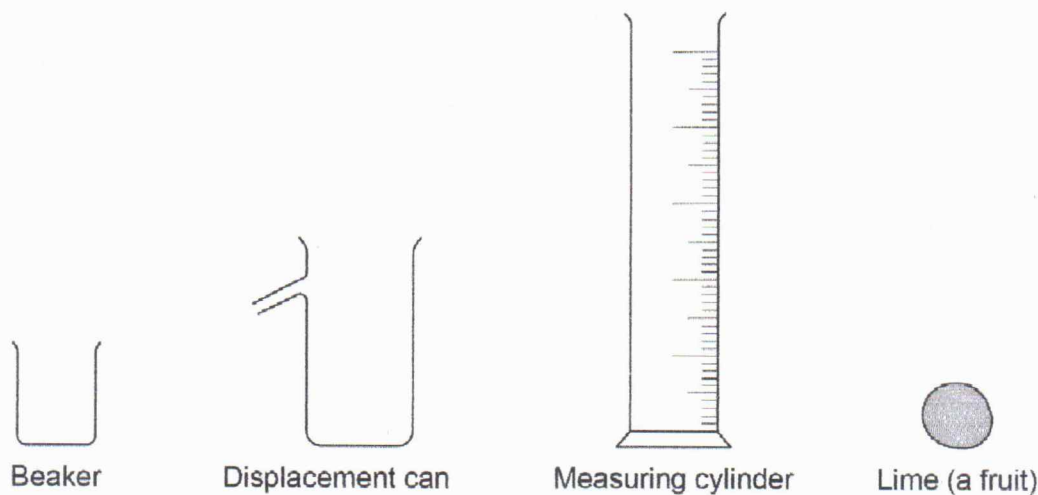

0 3 . 1

Describe a method the student could have used to measure the volume of the lime.

[4 marks]

- Using the Measuring Cylinder, partially fill the Measuring Cylinder and note the initial reading.
- Gently put the lime inside the Measuring Cylinder and note the new reading.
- Calculate the Volume change which is equal to the Volume of the lime:

$$\text{new Volume reading} - \text{initial Volume} = \text{Volume of Lime}$$



0 3 . 2

The student measured the volume of each fruit three times and then calculated a mean value.

The three measurements for a grape were

2.1 cm³ 2.1 cm³ 2.4 cm³

Calculate the mean value.

[2 marks]

$$\frac{2.1 + 2.1 + 2.4}{3} = 2.2 \text{ cm}^3$$

Mean value = 2.2 cm³

0 3 . 3

What are the advantages of taking three measurements and calculating a mean value?

[2 marks]

Tick (✓) **two** boxes.

Allows anomalous results to be identified and ignored.

Improves the resolution of the volume measurement.

Increases the precision of the measured volumes.

Reduces the effect of random errors when using the equipment.

Stops all types of error when using the equipment.

Question 3 continues on the next page

Turn over ►



0 3 . 4

The mass of an apple was 84.0 g.

The volume of the apple was 120 cm³.

Calculate the density of the apple.

Give your answer in g/cm³.

Use the equation:

$$\text{density} = \frac{\text{mass}}{\text{volume}}$$

[2 marks]

$$= \frac{84.0}{120}$$

$$= 0.70 \text{ g/cm}^3$$

Density = 0.70 g/cm³

10



0 4

A student investigated how the current in a circuit varied with the number of lamps connected in parallel in the circuit.

Figure 4 shows the circuit with three identical lamps connected in parallel.

Figure 4

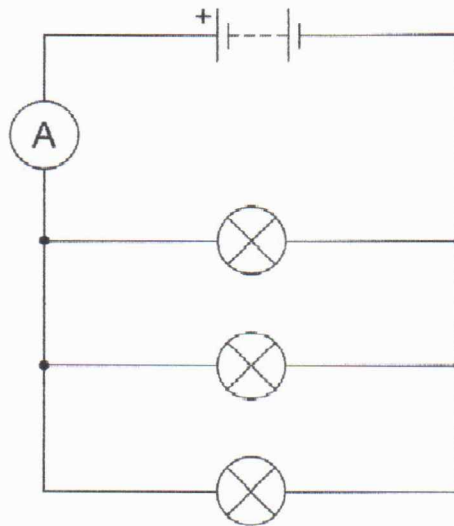
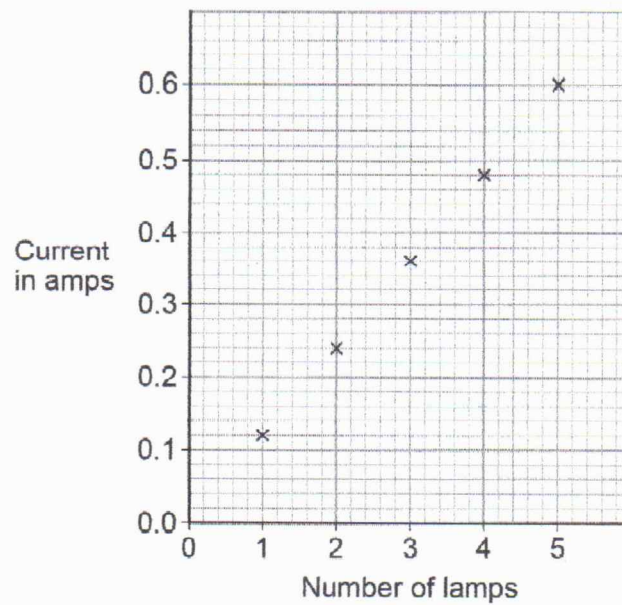

Figure 5 shows the results.

Figure 5



0 4 . 1

Complete the sentences.

Choose answers from the box.

Each answer can be used once, more than once or not at all.

decreased	stayed the same	increased
-----------	-----------------	-----------

[3 marks]

As the number of lamps increased, the current increased.As the number of lamps increased, the total resistance of the circuit decreased.

$$\left[I \propto \frac{1}{R} \right]$$

As the number of lamps increased, the potential difference across the battery stayed the same.

(in a parallel
cct V is
the same)

0 4 . 2

When there were three lamps in the circuit the ammeter reading kept changing between 0.35 A and 0.36 A.

What type of error would this lead to?

[1 mark]

Tick (✓) one box.

Random error

Systematic error

Zero error

Question 4 continues on the next page

Turn over ►



Figure 6 shows a circuit with five ammeters and three identical lamps.

Figure 6

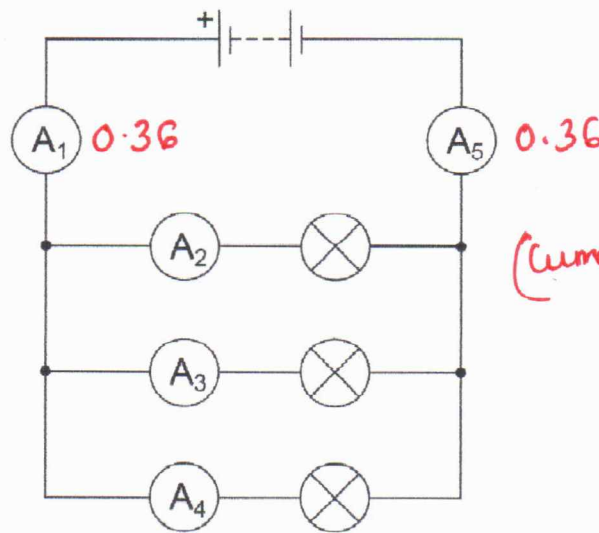

0 4 . 3

Complete Table 2 to show the readings on ammeters A_2 and A_5 .

[2 marks]

Table 2

Ammeter	A_1	A_2	A_3	A_4	A_5
Current in amps	0.36	0.12	0.12	0.12	0.36

↑
they are identical so have
the same current.



0 4 . 4

The resistance of one lamp is 15 Ω .

The current in the lamp is 0.12 A.

Calculate the power output of the lamp.

Use the equation:

$$\text{power} = (\text{current})^2 \times \text{resistance}$$

$$\text{Resistance} = 15$$

$$\text{Current} = 0.12$$

$$P = I^2 \times R$$

$$= 0.12^2 \times 15 = 0.216 \text{ W}$$

Power = 0.216 W

[2 marks]

8

Turn over for the next question

Turn over ►



0 5

Atoms of different elements have different properties.

0 5 . 1

Which of the following is the same for all atoms of the same element?

[1 mark]

Tick (✓) one box.

Atomic number

Mass number

Neutron number

Mass number
Atomic Number
← element

0 5 . 2

Which of the following is different for isotopes of the same element?

[1 mark]

Tick (✓) one box.

Number of electrons

Number of neutrons

Number of protons

Question 5 continues on the next page

Turn over ►



0 5 . 3

A nucleus emits radiation.

Figure 7 shows how the mass number and the atomic number change.

The nucleus is labelled D.

Figure 7

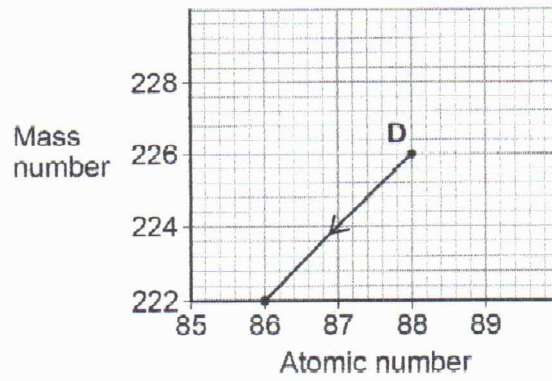

Which type of radiation is emitted when nucleus D decays?

Tick (✓) one box.

Alpha

Beta

Neutron

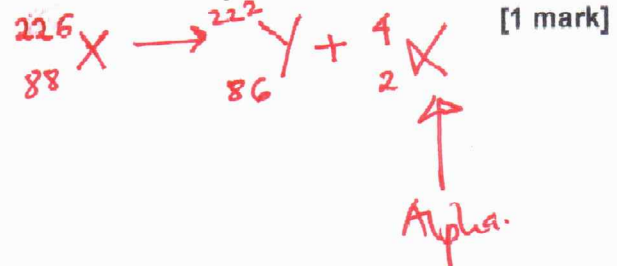

0 5 . 4 Nucleus E also emits radiation.

Figure 8 shows how the mass number and the atomic number change for nucleus E.

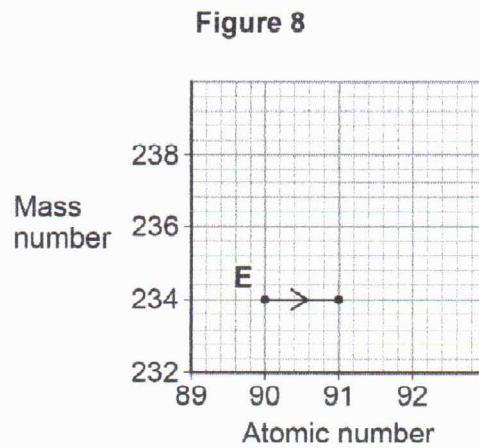

Which type of radiation is emitted when nucleus E decays?

Tick (✓) **one** box.

Alpha

Beta

Neutron

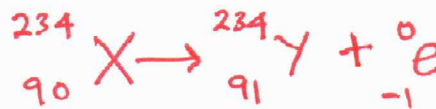

[1 mark]

Question 5 continues on the next page

Turn over ►



Beta radiation can be used to monitor the thickness of paper during production.

Figure 9 shows how the radiation is used.

Figure 9

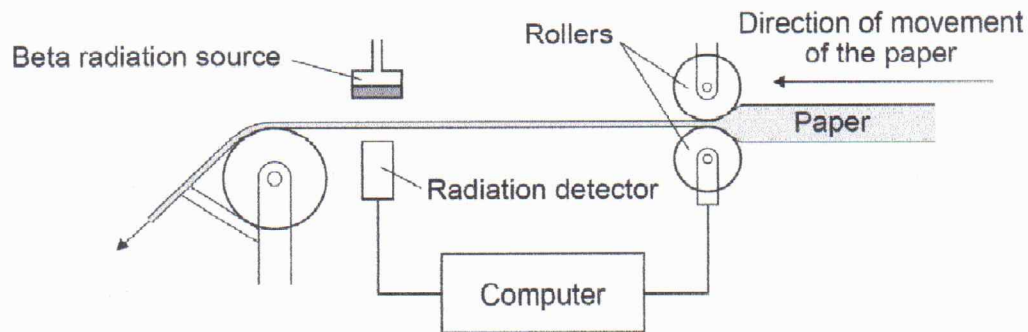

The computer uses information from the radiation detector to change the size of the gap between the rollers.

0 5 . 5

Complete the sentences.

Choose answers from the box.

Each answer can be used once, more than once or not at all.

decrease

stay the same

increase

The thickness of the paper between the beta source and the detector increases.

[2 marks]

The reading on the detector will decrease.

This is because the amount of radiation absorbed by the paper

will increase.



0 5 . 6 All radioactive elements have a half-life.

What is meant by 'half-life'?

[1 mark]

Tick (✓) one box.

The time it takes for all the nuclei in a radioactive sample to split in half.

The time it takes for the count rate of a radioactive sample to halve.

The time it takes for the radiation to travel half of its range in air.

0 5 . 7 Why should the radiation source used in **Figure 9** have a long half-life?

[1 mark]

Tick (✓) one box.

So the activity of the source is approximately constant.

So the amount of radiation decreases quickly.

So the radiation has a long range in air.

8

Turn over for the next question

Turn over ►



0 6

Figure 10 shows a house with a solar power system.

The solar cells generate electricity.

When the electricity generated by the solar cells is not needed, the energy is stored in a large battery.

Figure 10

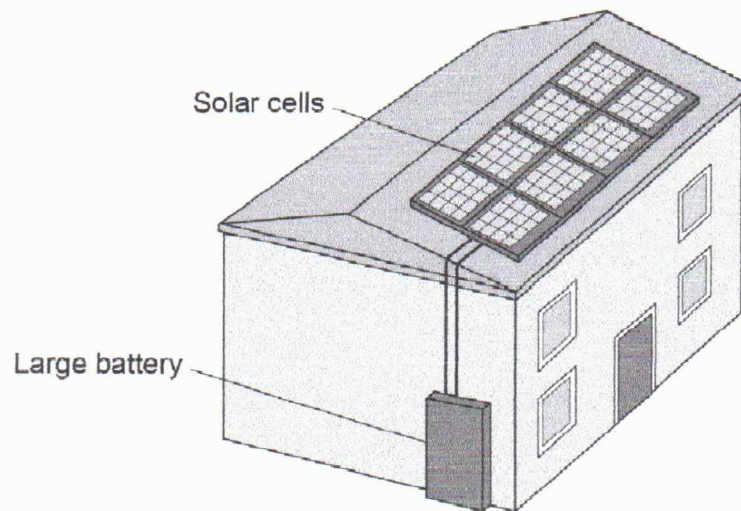

0 6 . 1

The solar cells on the roof of the house always face in the same direction.

Explain **one** disadvantage caused by the solar cells only facing in one direction.

[2 marks]

Solar cells do not automatically track the sun through the sky and so they will not receive maximum intensity of solar radiation.



0 6 . 2

The mean current from the solar cells to the battery is 3.5 A.

Calculate the charge flow from the solar cells to the battery in 3600 seconds.

Use the equation:

$$\text{charge flow} = \text{current} \times \text{time}$$

[2 marks]

$$= 3.5 \times 3600$$

$$= 12,600 \text{ C}$$

$$\text{Charge flow} = \underline{12,600} \text{ C}$$

0 6 . 3

Write down the equation which links efficiency, total power input and useful power output.

[1 mark]

$$\text{Efficiency} = \frac{\text{useful power output}}{\text{total power input}}$$

0 6 . 4

At one time in the day, the total power input to the solar cells was 7500 W.

The efficiency of the solar cells was 0.16

Calculate the useful power output of the solar cells.

[3 marks]

$$\text{useful power output} = \text{Efficiency} \times \text{Total power input.}$$

$$= 0.16 \times 7500$$

$$= 1200$$

$$\text{Useful power output} = \underline{1200} \text{ W}$$

Question 6 continues on the next page

Turn over ►



0 6 . 5

The wasted energy that is **not** usefully transferred by the solar cells is dissipated.

What happens to energy that has been dissipated?

[1 mark]

Tick (✓) **one** box.

The energy becomes less useful.

The energy is destroyed.

The energy is used to generate electricity.

0 6 . 6

Why is it unlikely that all the UK's electricity needs could be met by solar power systems?

[1 mark]

Tick (✓) **one** box.

A very large area would need to be covered with solar cells.

Solar power is a non-renewable energy resource.

The efficiency of solar cells is too high.

10



0 7

Figure 11 shows a diver about to dive off a diving board.

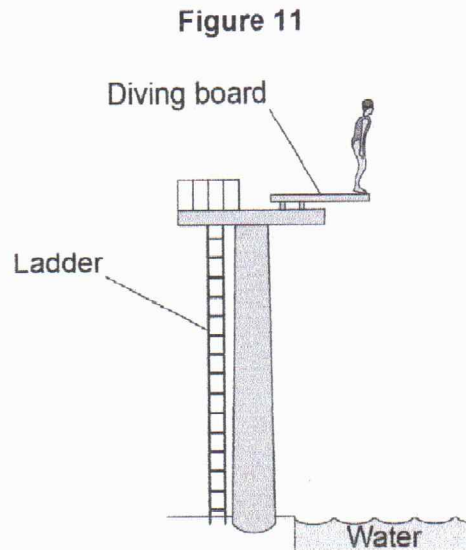

0 7 . 1

Complete the sentences.

Choose answers from the box.

[2 marks]

elastic potential

gravitational potential

kinetic

nuclear

As the diver falls towards the water there is a decrease in

her gravitational potential energy.

As the diver falls towards the water there is an increase in

her kinetic energy.

$$GPE = mgh$$

↑
(As height decreases)

(As the speed increases)

(As the speed increases)



0 7 . 2 Write down the equation which links kinetic energy (E_k), mass (m) and speed (v).

[1 mark]

$$E_k = \frac{1}{2} \times m \times v^2$$

0 7 . 3 At the instant the diver hits the water, the kinetic energy of the diver is 5040 J.

The speed of the diver is 12 m/s.

Calculate the mass of the diver.

[3 marks]

$$\text{mass} = \frac{2 E_k}{v^2} = \frac{2 \times 5040}{12^2} = 70 \text{ kg.}$$

Mass = 70 kg

0 7 . 4 Most of the kinetic energy of the diver is transferred to the water.

How does this affect the thermal energy of the water?

[1 mark]

Tick (✓) one box.

The thermal energy decreases.

The thermal energy stays the same.

The thermal energy increases.

7

Turn over for the next question

Turn over ►



0 8

A teacher demonstrated the relationship between the pressure in a gas and the volume of the gas.

Figure 12 shows the equipment used.

Figure 12

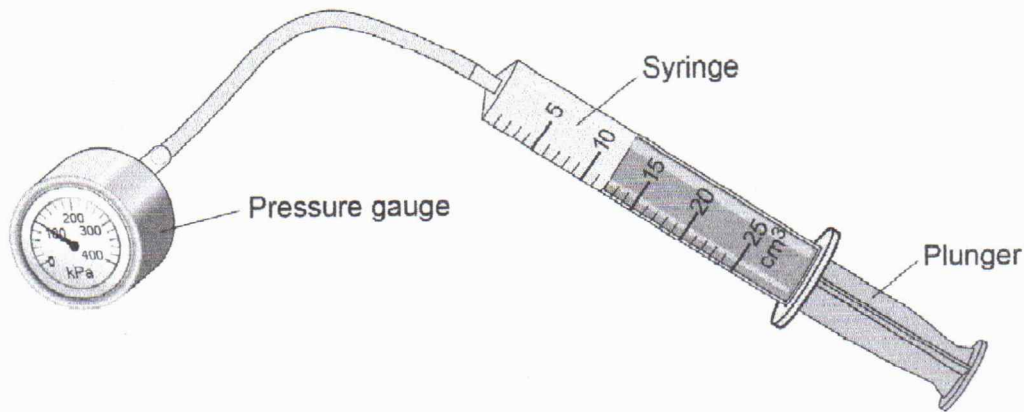

0 8 . 1

What is the range of the syringe?

[1 mark]

Tick (✓) **one** box.

From 0 to 1 cm³

From 0 to 5 cm³

From 0 to 25 cm³

0 8 . 2

The relationship between the pressure and volume of a gas is given by the equation:

$$\text{pressure} \times \text{volume} = \text{constant}$$

Complete the sentence.

For this equation to apply, both the mass of gas and the

of the gas must stay the same.

→ Controlled variables,
temperature

[1 mark]

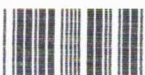

08.3

The initial volume of the gas in the syringe was 12 cm^3 .The initial pressure of the gas in the syringe was $101\,000 \text{ Pa}$.

Calculate the constant in the equation below.

pressure \times volume = constant

$$101,000 \times 12 = 1,212,000$$

[2 marks]

Constant = 1,212,000 Pa cm^3

08.4

The teacher pulled the plunger slowly outwards and the gas expanded.

The new volume of the gas was 24 cm^3 .

Calculate the new pressure in the gas.

The constant has the same value as in Question 08.3

[3 marks]

$$V_1 = 12$$

$$P_1 V_1 = P_2 V_2$$

$$P_1 = 101,000$$

$$P_2 = \frac{P_1 \times V_1}{V_2} = \frac{101,000 \times 12}{24}$$

$$V_2 = 24$$

$$P_2 = ?$$

$$= 50,500 \text{ Pa}$$

New pressure = 50,500 Pa

Question 8 continues on the next page

Turn over ►



Do not write
outside the
box

0 8 . 5

Which change occurs when the plunger is pulled slowly outwards?

[1 mark]

Tick (✓) one box.

The gas particles stop moving.

There are more frequent collisions between the gas particles.

There is more space between the gas particles.

8



0 9

Figure 13 shows an electric car being recharged.

Figure 13

Charging station

Power cable



0 9 . 1

The charging station applies a direct potential difference across the battery of the car.

What does 'direct potential difference' mean?

[1 mark]

The polarity does not
change.

Question 9 continues on the next page

Turn over ►

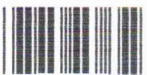

0 9 . 2 Which equation links energy transferred (E), power (P) and time (t)?

[1 mark]

Tick (✓) one box.

energy transferred = $\frac{\text{power}}{\text{time}}$

energy transferred = $\frac{\text{time}}{\text{power}}$

energy transferred = power \times time

energy transferred = power² \times time

0 9 . 3 The battery in the electric car can store 162 000 000 J of energy.

The charging station has a power output of 7200 W.

Calculate the time taken to fully recharge the battery from zero.

[3 marks]

$$\text{time} = \frac{\text{Energy transferred}}{\text{Power}}$$

$$= \frac{162,000,000}{7200} = 22,500$$

Time taken = 22,500 s

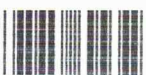

0 9 . 4 Which equation links current (I), potential difference (V) and resistance (R)?

[1 mark]

Tick (✓) one box.

$I = V \times R$

$I = V^2 \times R$

$R = I \times V$

$V = I \times R$

0 9 . 5 The potential difference across the battery is 480 V.

There is a current of 15 A in the circuit connecting the battery to the motor of the electric car.

Calculate the resistance of the motor.

[3 marks]

$$R = \frac{V}{I} = \frac{480 \text{ V}}{15 \text{ A}}$$

$$R = 32 \Omega$$

Resistance = 32 Ω

Question 9 continues on the next page



0 9 . 6

Different charging systems use different electrical currents.

- Charging system **A** has a current of 13 A.
- Charging system **B** has a current of 26 A.
- The potential difference of both charging systems is 230 V.

How does the time taken to recharge a battery using charging system **A** compare with the time taken using charging system **B**?

[1 mark]

Tick (✓) **one** box.Time taken using system **A** is half the time of system **B**Time taken using system **A** is the same as system **B**Time taken using system **A** is double the time of system **B**

10

1 0

Energy from the Sun is released by nuclear fusion.

1 0 . 1

Complete the sentences.

[2 marks]

Nuclear fusion is the joining together of nuclei.During nuclear fusion the total mass of the particles decreases.

1 0 . 2

Nuclear fusion of deuterium is difficult to achieve on Earth because of the high temperature needed.

Electricity is used to increase the temperature of 4.0 g of deuterium by 50 000 000 °C.

specific heat capacity of deuterium = 5200 J/kg °C

Calculate the energy needed to increase the temperature of the deuterium by 50 000 000 °C.

Use the Physics Equations Sheet.

[3 marks]

$$\Delta E = mc \Delta \theta$$

$$= \frac{4}{1000} \text{ kg} \times 5200 \times 50,000,000$$

$$= 1.04 \times 10^9 \text{ J}$$

Energy = 1.04 × 10⁹ J

1 0 . 3

The idea of obtaining power from nuclear fusion was investigated using models.

The models were tested before starting to build the first commercial nuclear fusion power station.

Suggest **two** reasons why models were tested.

[2 marks]

1 To verify the possibility of nuclear fusion.

2 To make the adaptations to the process.

1 0 . 4

Generating electricity using nuclear fusion will have fewer environmental effects than generating electricity using fossil fuels.

Explain **one** environmental effect of generating electricity using fossil fuels.

[2 marks]

Releases sulphur dioxide which causes acidic rain

9

Turn over for the next question

Turn over ►



1 1

Student A investigated how the current in resistor R at constant temperature varied with the potential difference across the resistor.

Student A recorded both positive and negative values of current.

Figure 14 shows the circuit Student A used.

Figure 14

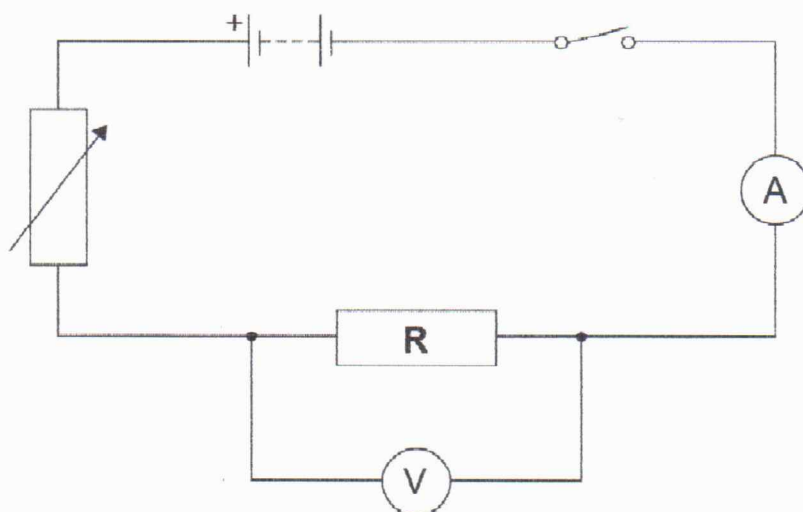

1 1 . 1

Describe a method that Student A could use for this investigation.

[6 marks]

- After setting up the apparatus as shown above.
- Measure the current across R using the ammeter A, then obtain the P.d across the resistor from Voltmeter V.
- Vary the resistance of the variable resistor and note new pair of values for V and A.
- Repeat for a range of values and ensure the current is low to avoid temperature rise.
- Plot a graph of current against P.d.



- Ensure the switch is off between readings.

1 1 . 2 Student B repeated the investigation.

During Student B's investigation the temperature of resistor R increased.

Explain how the increased temperature of resistor R would have affected Student B's results.

[2 marks]

Resistance of R would increase
and current and P/d would not
be directly proportional.

Question 11 continues on the next page

Turn over ►



Figure 15 shows the scale on a moving coil ammeter at one time in the investigation.

Figure 15

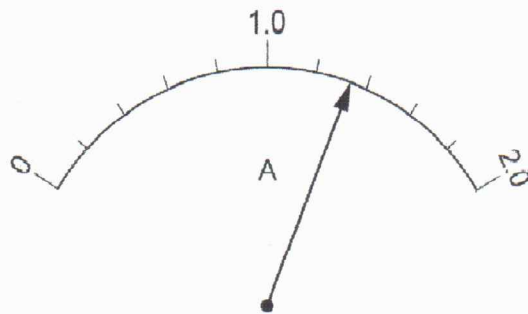

1 1 . 3

What is the resolution of the moving coil ammeter?

(The least reading possible)

[1 mark]

Resolution = 0.2 A

$$\frac{1.0}{5} = \underline{\underline{0.2 \text{ A}}}$$



1 1 . 4 Student B replaced the moving coil ammeter with a digital ammeter.

Figure 16 shows the reading on the digital ammeter.

Figure 16

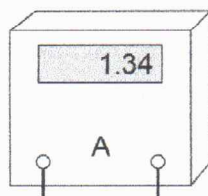

The digital ammeter has a higher resolution than the moving coil ammeter.

Give **one** other reason why it would have been better to use the digital ammeter throughout this investigation.

[1 mark]

There would be no parallax error
during taking readings.

10

END OF QUESTIONS

